

$I = \frac{P}{V}$   $V_{gens}$

T.D

$R_s = 16$

2/1/19

Transmission, Distribution & Utilisation

PAGE NO.   
 DATE: / /

1. Transmission system

Typical AC Power System Network:

A large power system network from generating station to the consumer's end is broadly divided into Transmission and Distribution.

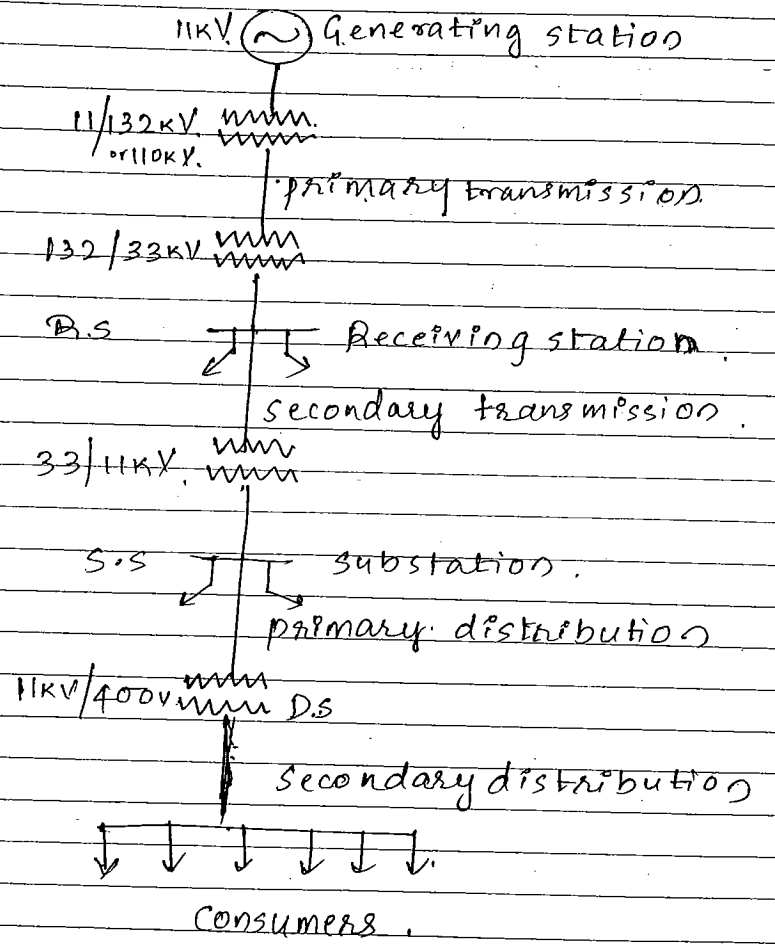

layout of typical a.c power supply network

Each part can be subdivided into primary transmission & secondary transmission & primary distribution & secondary distribution.

i) Generating station (G.S): G.S represents the generating station where electric power is produced by 3 phase alternators operating in parallel. The voltage of generation is 6.6 kV, 11 kV or 22 kV. For simplicity & economy power is generated at 11 kV. For economy in the transmission of electric power, the voltage is stepped up to (110 kV) or 132 kV at generating station with the help of 3 ph transformers.

The transmission of electric power at high voltages has advantages including saving of conductor material & high transmission efficiency.

(4)

ii) Primary transmission: The electric power at 132 kV is transmitted by 3 phase - 3 wire overhead system to the outskirts of the city. This forms primary transmission.

iii) Secondary transmission: The primary transmission line terminates at the receiving station (RS) which lies at the outskirts of the city. At receiving station, the voltage is reduced to 33 kV by stepdown taps. From this station electric power is transmitted at 33 kV by 3 ph 3 wire overhead system to various substation (SS) at strategic points in the city. This forms secondary transmission.

iv) Primary distribution: The secondary transmission line terminates at substation (SS) where voltage is reduced from 33 kV to 11 kV 3 phase 3 wire. The 11 kV lines run along important road sides of the city. This forms primary distribution. Big consumers are generally supplied power at 11 kV for further handling with their own substation (if demand is > 50 kW).

v) Secondary distribution. The electric power from primary distribution line (11 kV) is distributed to distribution substation. These substations are located near consumers localities & step down the voltage to 400 V - 3 ph 4 wire. for secondary distribution.

The voltage between any two phases is 400 V. The voltage between any phase & neutral is 230 V. The single ph residential lighting load is connected between any one phase & neutral.

\* Standard transmission & distribution voltages  
The standard voltage ratings used for transmission & distribution is as given below

- 1) Generation - 6.6KV, 11KV, 22KV or 33KV
- 2) Primary transmission - 110KV or 220KV
- 3) Secondary transmission - 66KV or 33KV
- 4) Primary distribution - 11KV
- 5) Secondary distribution - For AC 440V b/w phase & 230V b/w phase & neutral.  
For DC - 110V or 220V

\*\* Advantages & Disadvantages of High voltage transmission

Advantages

- 1) Reduces volume of conductor material.
- considers transmission of electric power by 3 ph line

$$I = \text{load current} = \frac{P}{\sqrt{3} \cos \phi \cdot V}$$

$$R = \frac{\rho l}{a}$$

$$\begin{aligned} \text{Total Power loss} &= 3 I^2 R \\ &= 3 \left( \frac{P}{\sqrt{3} \cos \phi \cdot V} \right)^2 \frac{\rho l}{a} \end{aligned}$$

$$Wl = \frac{P^2 \rho l}{V^2 \cos^2 \phi \cdot a}$$

$$\text{Area of cross section } a = \frac{P^2 \rho l}{W V^2 \cos^2 \phi}$$

$$\begin{aligned} \text{Total volume of conductor material} &= 3 a l \\ &= 3 \times \frac{P^2 \rho l^2}{W V^2 \cos^2 \phi} \end{aligned}$$

As voltage increases, area of conductor decreases.

- 2) High power transmissibility of AC line  $P \propto V^2$
  - 3) Line losses decrease with increase of transmission voltage & improvement of pf for same power transfer. i.e. increases transmission efficiency.
- $$\text{Transmission } \eta = \left[ \frac{1 - \sqrt{3} I \rho l}{V \cos \phi} \right]$$

Decrease in percentage line drop

$$\begin{aligned} \text{line drop} &= IR = I \times \frac{\rho l}{a} \\ &= I \times \rho l \times \frac{1}{a} = \frac{\rho l I}{a} \end{aligned}$$

$$\% \text{age line drop} = \frac{\rho l I}{V} \times 100$$

As  $\rho, l, I$  are constant %age line drop decreases when transmission voltage increases.

- 5) Bulk power transfer from large group of generating stations up to main transmission network.

Disadvantages of HV transmission

- 1) The increased cost of insulating of the conductors.
- 2) The increased cost of transformers, switchgear & terminal apparatus.
- 3) short circuit levels: In case of very long lines above 500km intermediate switching substations are necessary to ~~limit~~ install shunt reactors for compensation.

- 4) In some cases of big consumers, industrial localities it is impossible to acquire right of way for EHV AC lines.

Various systems for power transmission & distribution.

- i) Direct current system.
  - a) Two wire DC system
  - b) Two wire DC with midpoint earthed.
  - c) DC three wire
- ii) AC single phase system.
  - a) Single phase two wire
  - b) single ph two wire with midpoint earthed
  - c) Single ph three wire
- iii) AC two phase system.
  - a) Two phase four wire system
  - b) Two phase three wire system.
- iv) AC three phase system.
  - a) three ph three wire system.
  - b) Three ph four wire system.

For overhead system: For comparing different systems, let the similar conditions will be assumed in each case.

- i) Same amount of power is transmitted by each system - P watts
- ii) Distance of transmission is same for each system - 'l' mts.
- iii) The line losses  $I^2R$  is same in each s/m say 'W' watts
- iv) The max m voltage in each s/m is same say  $V_m$  volts.

case 1 Two wire DC.

In this system one is positive wire & another is negative wire which is connected to earth.

Maxm voltage b/w conductors =  $V_m$   
power to be transmitted = P  
Load current  $I = P/V_m$

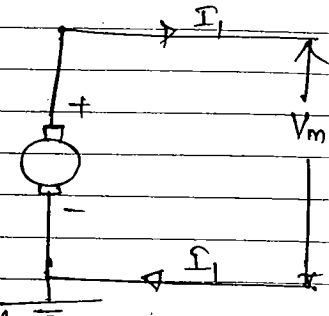

If  $R_1$  is the resistance of each line conductor then,

$$R_1 = \frac{\rho l}{a_1}$$

Where  $a_1$  is the area of X-section of conductor  
Line losses or copper loss in both conductors = 'W'

$$\begin{aligned} W &= 2 I^2 R_1 \\ &= 2 \left( \frac{P}{V_m} \right)^2 R_1 \\ &= 2 \left( \frac{P}{V_m} \right)^2 \frac{\rho l}{a_1} \\ &= 2 \frac{P^2 \rho l}{V_m^2 a_1} \end{aligned}$$

$$\therefore \text{area of cross section } a_1 = \frac{2 P^2 \rho l}{V_m^2 W}$$

Volume of conductor material required =  $2 a_1 l$ .

$$\begin{aligned} &= 2 \times \frac{2 P^2 \rho l}{V_m^2 W} \cdot l \\ &= \frac{4 P^2 \rho l^2}{W V_m^2} = K \end{aligned}$$

Case 2 Single ph two wire AC.  
In this system single phase ac is supplied through two conductors in which one conductor is neutral is earthed as shown in fig.

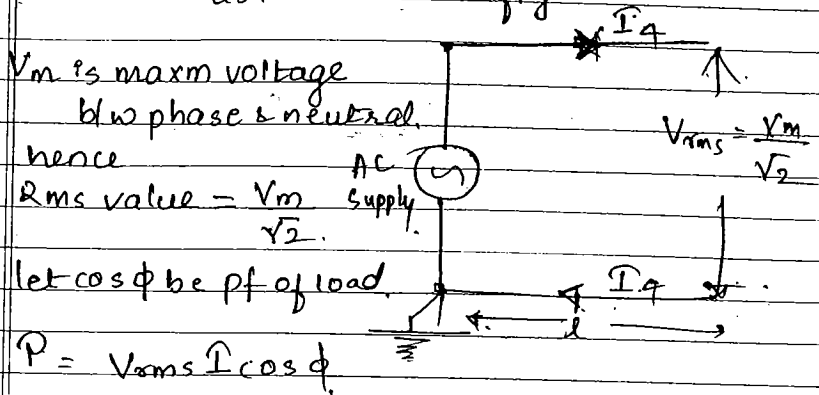

Load current  $I_l = \frac{P}{\left(\frac{V_m}{\sqrt{2}}\right) \cos \phi} = \frac{\sqrt{2} P}{V_m \cos \phi}$

Let  $a_l$  be area of cross section of conductor  
Line losses  $W = 2 I_l^2 R_l$

$$= 2 \left( \frac{\sqrt{2} P}{V_m \cos \phi} \right)^2 \frac{\rho l}{a_l}$$

$$W = \frac{4 P^2 \rho l}{\cos^2 \phi V_m^2 a_l}$$

$$a_l = \frac{4 P^2 \rho l}{\cos^2 \phi V_m^2 W}$$

Volume of conductor material required  
 $= 2 a_l l = 2 \left( \frac{4 P^2 \rho l}{\cos^2 \phi V_m^2 W} \right) l$

$$= \frac{8}{\cos^2 \phi} \times \frac{P^2 \rho l^2}{W}$$

Case 3: Single phase 3 wire system AC.  
In this system single phase ac is supplied through three conductors i.e. two outer and neutral wire is taken from the mid. point of phase winding.  
If load is balanced, the current through neutral wire is zero.  
Assuming balanced load.

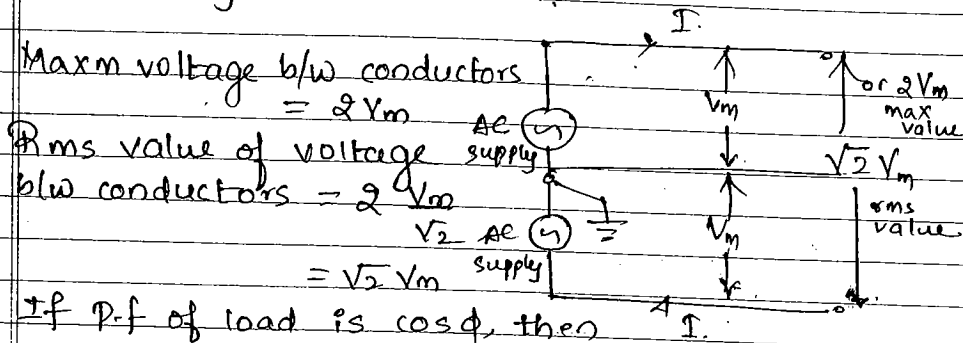

Let  $a$  be area of x section of each outer conductor

Line losses  $W = 2 I^2 R$

$$= 2 \left( \frac{P}{\sqrt{2} V_m \cos \phi} \right)^2 \frac{\rho l}{a}$$

$$W = \frac{P^2 \rho l}{V_m^2 \cos^2 \phi a}$$

$\therefore$  Area of x section  $a = \frac{P^2 \rho l}{W V_m^2 \cos^2 \phi}$

Assuming area of x section of neutral wire to be half of outer wire

Volume of conductor material  $= 2.5 a l$   
 $= 2.5 \times \frac{P^2 \rho l^2}{W V_m^2 \cos^2 \phi}$

volume of conductor =  $\frac{2.5 \cdot P^2 \ell^2}{\cos^2 \phi \cdot W V_m^2}$

multiply & divide by 4

$$= \frac{2.5 \cdot 4 P^2 \ell^2}{\cos^2 \phi \cdot 4 W V_m^2}$$

$$= \frac{2.5 \cdot 4 P^2 \ell^2}{\frac{10}{2} \times 4 \cos^2 \phi \cdot W V_m^2}$$

$$= \frac{5}{8 \cos^2 \phi} K$$

3 phase 3 wire system.

This system is almost universally adopted for transmission of electric power. The 3 ph 3 wire system may be star connected or delta connected.

The neutral point N is earthed

power transmitted/ph =  $P/3$

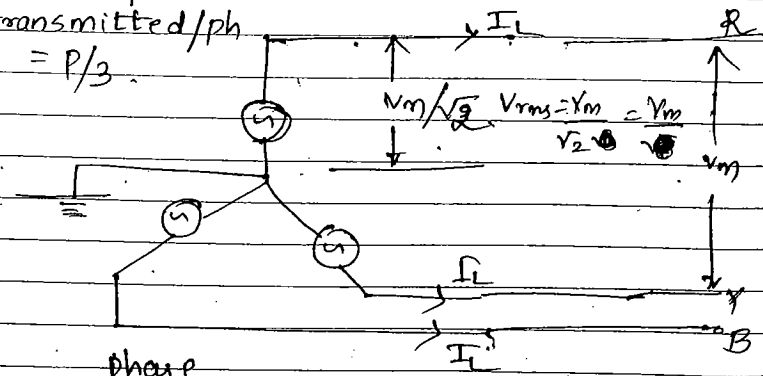

$V_m$  is max voltage b/w two lines  
hence phase voltage =  $\frac{V_m}{\sqrt{2}} = \frac{V_m}{\sqrt{2}}$

Rms value of voltage =  $\frac{V_m}{\sqrt{2}} = \frac{V_m}{\sqrt{2}}$

power supplied/phase =  $P/3$

Load current/phase =  $\frac{\text{power/ph}}{\text{voltage/ph} \times \cos \phi}$

$$I = \frac{P/3}{\frac{V_m \times \cos \phi}{\sqrt{2}}}$$

$$= \frac{\sqrt{2} P}{3 V_m \cos \phi}$$

Let R is resistance of conductor a is cross section area of conductor

Line losses  $W = 3 I^2 R$

$$= 3 \left( \frac{\sqrt{2} P}{3 V_m \cos \phi} \right)^2 \frac{\rho l}{a}$$

$$W = 3 \times 2 \frac{P^2 \rho l}{9 V_m^2 \cos^2 \phi a}$$

Area of x section of conductor  $a = \frac{2 P^2 \rho l}{3 V_m^2 \cos^2 \phi W}$

Volume of conductor =  $3 a l$

$$= 3 \times \frac{2 P^2 \rho l}{3 V_m^2 \cos^2 \phi W} \times l$$

$$= \frac{2 P^2 \rho l^2}{W V_m^2 \cos^2 \phi}$$

$$= \frac{0.5 K}{\cos^2 \phi}$$

3 phase 4 wire AC System

In this case 4th or neutral wire is taken from neutral point. The area of x section of neutral wire is generally one half that of line conductor. considering loads are balanced current through neutral wire is zero.

Line losses  $W =$  Same as 3 ph 3 wire

$$W = \frac{2 p^2 l}{3 a v_m^2 \cos^2 \phi}$$

Area of x section  $a = \frac{2 p^2 l}{3 W v_m^2 \cos^2 \phi}$

∴ Volume of conductor material =  $3.5 a l$

$$= 3.5 \times \frac{2 p^2 l}{3 W v_m^2 \cos^2 \phi} \cdot l$$

$$= \frac{3.5 \times 2 \times 4 p^2 l^2}{3 \cdot 4 W v_m^2 \cos^2 \phi}$$

$$= \frac{7 K}{12 \cos^2 \phi}$$

$$= \frac{0.5833 K}{\cos^2 \phi}$$

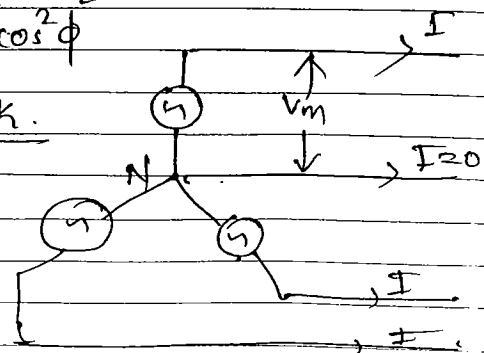

Advantages & Disadvantages of DC & AC power transmission.

Advantages of DC transmission.

- ① The DC transmission system require only two conductors. Even power can be transmitted by one conductor by using earth as a return conductor, hence much conductor material is saved.
- ② In DC transmission there is no problem of inductance, capacitance, phase displacement & surge problem.
- ③ In DC there is no skin effect hence full cross section of the conductor is utilised.
- ④ In DC insulation required will be less because for a given voltage the potential stress on the insulation required will be less because for a given voltage in DC is  $1/\sqrt{2}$  times that of in AC.
- ⑤ Due to less potential stress & small dielectric losses DC can be used for underground cables.
- ⑥ Voltage regulation will be better in DC transmission.
- ⑦ The corona loss in DC is less, ∴ interference with communication line will be less.
- ⑧ In DC transmission there is no problem of synchronizing & stability.

Disadvantages of DC transmission:

- ① DC electrical power cannot be generated at a high voltage because of commutation difficulties.

- ② Transformers cannot be used for step up & down the dc voltage.
- ③ The switches & CB. are used for DC have their own limitations.

Advantages of AC transmission.

- ① AC power can be generated at high voltage easily.
- ② The maintenance of AC substation is cheap & easy compared to DC substation.
- ③ Transformers can be used for changing the voltage level which are easier & efficient for transmission & distribution.

Disadvantages of AC transmission.

- ① Amount of conductor material required is more.
- ② In long AC transmission line charging current flows due to capacitance effect produces continuous power loss.
- ③ The construction of AC line is complicated than DC line.

- ④ The effective resistance of the transmission line is increased in AC due to skin effect.
- ⑤ To avoid corona losses and to provide adequate insulation the spacing between the line conductors is kept more in AC compared to DC.

Comparison between overhead & underground transmission lines.

Slm. "Reference" underground cables Overhead System

|   |                                |         |
|---|--------------------------------|---------|
| ① Initial cost                          | high                           | low     |
| ② Maintenance cost                      | low                            | high    |
| ③ Public safety                         | more                           | less    |
| ④ chances of fault                      | less                           | more    |
| ⑤ Chances of accidents                  | very low                       | more    |
| ⑥ Appearance                            | Good                           | Bad     |
| ⑦ Voltage drop                          | low (Due to less inductance)   | high.   |
| ⑧ Fault location                        | Difficult                      | Easy    |
| ⑨ Repairing                             | Difficult                      | Easy    |
| ⑩ Interference with communication lines | None                           | Present |
| ⑪ Joining                               | Difficult                      | Easy    |
| ⑫ Charging current                      | high (due to high capacitance) | low     |

Advantages & Disadvantages of underground System over OHL.

Advantages:

- ① Transmission s/m is not subjected to interruption of supply caused by lightning thunder storms, birds & other weather conditions.



- ② Transmission system is free from road accidents.
- ③ The chances of breaking conductors is less, hence it reduces accident & interruption of supply.
- ④ Using of underground does not spoil beauty of city.
- ⑤ The maintenance required is less.
- ⑥ Underground cable system is more safer than overhead system.
- ⑦ Due to less spacing b/w the conductors, the inductance is low hence voltage drop is low.
- ⑧ underground system does not interfere with communication lines.

Disadvantages

- 1) Initial cost is very high.
- 2) Underground s/m. cannot be used for very high voltages.
- 3) Fault finding & repairing is difficult.
- 4) Time required for fault finding & repairing is more.
- 5) System draws high charging current.
- 6) Jointing of cable is difficult. Hence tapping for loads & service mains is not convenient by using underground cable s/m.

Transmission Tower Type & Design.

The main supporting unit of overhead transmission line is transmission tower which carries the heavy transmission conductors at a sufficient height from ground. In addition to that all towers have to sustain all kinds of natural calamities. So transmission tower designing is an important engineering job where all 3 concepts civil, mechanical & electrical concepts are applicable.

A power transmission tower consists of following parts:

- 1) Peak of transmission tower.
- 2) Cross arm of transmission tower.
- 3) Boom of transmission tower.
- 4) Cage of transmission tower.
- 5) Transmission tower body.
- 6) Leg of transmission tower.
- 7) Stub, Anchor Bolt & Base plate assembly of transmission tower.

Peak of Transmission tower: The portion above the top cross arm is called peak of transmission tower. Generally earth shield wire connected to tip of this peak.

Cross Arm of transmission tower: cross arms hold the transmission conductor. The dimensions

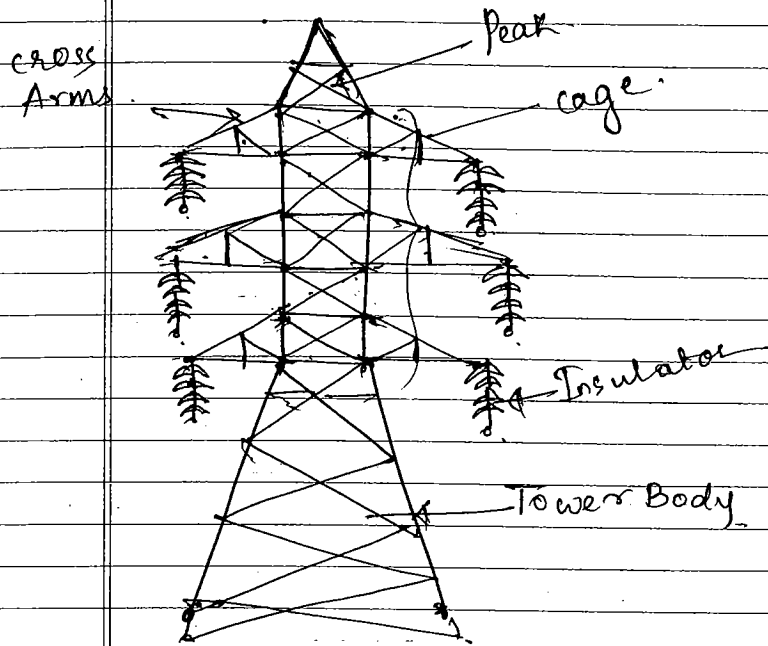

### Main Components of

its straight way when obstruction comes. In total length of a long transmission line there may be several deviation points.

According to angle of deviation there are 4 types of transmission tower.

- A-type tower - angle of deviation is  $0^\circ$
- B type tower - angle of deviation  $2-15^\circ$
- C type tower - angle of deviation  $15-30^\circ$
- D type tower - angle of deviation  $30-60^\circ$

As per force applied by the conductor on the cross arms, the transmission towers can be classified as

- ① Tangent suspension tower - A type
- ② Angle tower or Tension tower - B-C-D type

Cage of Transmission tower - The portion b/w tower body & peak is known as cage of transmission tower. This portion of tower holds the cross arms.

Transmission Tower Body: The portion from bottom cross arms upto ground level is called transmission tower body. This portion of the tower plays a vital role for maintaining required ground clearance of the bottom conductor of transmission line.

Types: The transmission line goes as per available corridors. Due to unavailability of shortest distance straight corridor transmission line has to deviate from

### Main components used in overhead transmission lines.

An overhead line may be used to transmit or distribute electric power while designing it should be ensured that mechanical strength of line is such so as to provide against probable weather conditions. The main components of overhead line are

- 1) conductors - which carry electric power from the sending end station to the receiving end station.
- 2) Supports - which may be poles or towers & keep the conductors at a suitable level above the ground.

- 3) Insulators - which are attached to supports & insulate the conductors from the ground.
- 4) Cross arms - which provide support to the insulators.
- 5) Miscellaneous items such as phase plates, danger plates, lightning arrestors, ant-climbing wire, guy sets.

Conductor Materials The proper choice of the material & size of the conductor is of considerable importance. The material should have following properties.

- ① High electrical conductivity.
- ② High tensile strength to withstand against mechanical stress.
- ③ Should have low weight.
- ④ The cost of material should be low.
- ⑤ The material should be easily available.
- ⑥ Low specific gravity so that weight/unit volume is small.

The most commonly used conductor materials are copper, Aluminium, ACSR (Aluminium conductor steel Reinforced), Iron & galvanized steel, Cadmium-copper.

Line Supports : The supporting structures for overhead line conductors are various types of poles or towers. The line supports should have following properties.

- ① High mechanical strength to withstand weight of conductors & wind loads.

- i) Light in weight without loss of mechanical strength.
- ii) cheap in cost & economical to maintain.
- iii) longer life.
- iv) Easy accessibility of conductors for maintenance.

The line supports used may be of various types including wooden poles, steel poles, R.C.C. poles & lattice steel towers.

The narrow based lattice steel towers are used for transmission at 33kV.

Broad based, lattice steel towers are used for 66kV & majority of long distance transmission, is carried by steel fabricated towers only, which are capable of withstanding in all climate conditions & are immune from destruction. The tower footings are efficiently grounded which reduces chances of accident due to atmospheric lightning.

Insulators : The function of insulator on an overhead transmission line is to insulate conductor from support & other parts. In overhead transmission & distribution line conductors are supported on the poles or towers. The fixing of conductors should be such that currents from the conductors do not flow to earth through supports. properties

- ① High mechanical strength in order to withstand conductor's load, wind pressure etc.
- ② Dielectric strength must be high.
- ③ They must be free from internal impurities.
- ④ High resistance in order to avoid

⑤ The ratio of Puncher strengths to flash over should be high.

⑥ Material used for insulator should be nonporous, should not be affected by change in temperature.

The common material used for insulator - PS porcelain

Different Types of Insulators

- ① Pin Type Insulator
- ② Suspension Type Insulator
- ③ Strain (Shackle) type insulator

Cross Arms To have proper insulation clearance to avoid birdage trouble & to avoid conductor clashing due to windage it is necessary that conductors in overhead lines are placed at suitable spacings.

Types of Cross Arms

- ① Teak wood
- ② G-I (Galvanized Iron)
- ③ Angle type
- ④ channel type

Miscellaneous Includes

Steps involved in Erection of Transmission Tower

- 1) Foundation: The foundation of towers are of chimney & frustrum type. The foundation pits are excavated to the depths mentioned in the foundation plan.

- 2) Stub setting: The portion of tower which goes into the foundation is called stub. Stub setting is to be done correctly in position to keep the tower square in alignment & to give correct slope of the leg member tower. Hence template is used for this.

→ The templates are located over the location.

At each horizontal member of template grooves are cut, through which strings are attached.

→ The intersection of strings gives the centre point of tower base.

This point should be made to coincide with nail point on the tower stake.

→ A string should be stretched in line with nail points on centre peg & two adjacent 5m pegs. Keeping the centre point of template over the nail point of centre peg, the template is adjusted such that string in it is in the direction of alignment is exactly superposed over the string stretched over the 3 pegs.

→ Then template is supported in position by firm wedged or screw jacks

→ At each corner of template a stub is fitted up.

→ The top of all stubs should be at one level

to ensure verticality of tower which is done by levelling instruments.

iii) Concreting of stubs: The stub after setting will be encased with concrete in shape according to drawings. The bottom half is in shape of truncated pyramid & top half, narrow neck of square section. The mixture of concrete is 1:2:4 cement: sand: Aggregates.

iv) Back filling: The back filling of pits is done with earth, stones, boulders removed from pits should be stacked inside tower base. The earth should be thoroughly wetted & consolidated in 15cm layer. The templates should be in correct position. The tops of concrete left above the ground level should be kept wet for 14 days.

v) Fabricating of towers when concreting becomes strong & solids. The angles of designed sizes are attached to each other starting from stubs. The fabrication of L section angles strips are jointed with required size of nut bolts as per supplied drawings under supervision.

## Line Constants Performance of Transmission Line.

The important consideration in the design & operation of a transmission line are the determination of voltage drop, line losses & efficiency of transmission. These values are greatly influenced by R, L & C of the transmission line.

An AC transmission line has resistance, inductance & capacitance uniformly distributed along its length. These are known as constant or parameters of line which describe the performance of transmission line i.e. voltage regulation, efficiency, line losses etc.

i) Resistance: It is the opposition of line conductor to the current flow. The resistance is distributed uniformly along the whole length of the line. For convenience, the performance of line can be analysed considering distributed resistance to be as lumped resistance.

The resistance of transmission line is given by  $R = \frac{\rho l}{a}$ .

The value of  $\rho$  specific resistance depends upon the temperature of line conductor. The resistance of line increases with temperature.

If  $R_{t_2}$  is resistance at  $t_2^\circ\text{C}$ ,  $R_{t_1}$  resistance at  $t_1^\circ\text{C}$ , then  $R_{t_2} = R_{t_1} [1 + \alpha(t_2 - t_1)]$

$\alpha$  - temperature coefficient of resistance.

2) Inductance of overhead transmission line  
 when AC is supplied to the transmission line, a changing flux sets up, which links the conductor. Due to this flux linkage, the conductor possess inductance.

Thus inductance of an AC circuit is defined as flux linkage/unit ampere

$$\text{Inductance } L = \frac{\text{Flux linkage}}{\text{current}}$$

$$= \frac{N\phi}{I} \text{ henry}$$

The inductance of a transmission line depends upon

- 1) Arrangement or configuration of conductors
- 2) No of phases i.e. 1 $\phi$  or 3 $\phi$
- 3) Type of conductor solid or stranded
- 4) Material of conductor
- 5) Dimension of conductor
- 6) Spacing b/w conductors

Capacitance of a transmission line:

In transmission line two conductors are separated as spacing by an insulating material constituting capacitor, two conductors are separated by air which acts as an insulation.  $\therefore$  capacitance exists between any two overhead line conductors

The capacitance b/w the conductors is the charge/unit potential

$$C = \frac{q}{V} \text{ charge on capacitance}$$

Classification of Overhead lines

overhead transmission lines are classified in many ways according to nature of current, voltage rating, distance of transmission line application etc.

According to distance i.e. length of transmission line, they are classified as

- 1) Short transmission line: when the length of an overhead TL is upto 80km & its voltage is below 20KV, the line is termed as short TL.
- 2) Medium TL: when the length of an overhead transmission line is in between 80km to 250km, & its voltage rating is b/w 20KV to 100KV then line is termed as medium transmission line.
- 3) Long TL: when the length of an overhead TL is above 250km & its voltage rating is above 100KV then line is termed as long transmission line

Important Terms

1) Voltage Regulation:

when the transmission line is loaded, the load current flows in a line, due there is a voltage drop in the line due to resistance & inductance of the line. the result is that receiving end ( $V_R$ ) voltage is generally less than sending end voltage ( $V_S$ ) ( $V_R < V_S$ ).

<sup>actual</sup>  
The voltage drop ( $V_S - V_R$ ) in the line is expressed as percentage of receiving end voltage  $V_R$  and is called as voltage regulation.

The difference in voltage at the receiving end of a transmission line between the conditions of no load and full load is called voltage regulation. It is expressed as percentage of receiving end voltage.

$$\% \text{ regulation} = \frac{V_S - V_R}{V_R} \times 100$$

$V_S$  = Sending end voltage

$V_R$  = Receiving end voltage.

### 2) Efficiency of Transmission line:

When the transmission line is loaded, the load current flows in line, due to presence of resistance, resistance losses i.e.  $I^2 R$  (power) losses takes place & hence receiving end power will be less than sending end power.

The ratio of receiving end power to the sending end power of a transmission line is known as transmission efficiency of the line i.e.

$$\% \text{ Transmission } \eta = \frac{\text{Receiving end power}}{\text{Sending end power}} \times 100$$

$$= \frac{V_R I_R \cos \phi}{V_S I_S \cos \phi} \times 100$$

where  $V_S$  = sending end voltage  
 $V_R$  = receiving end voltage  
 $I_S$  = sending end current  
 $I_R$  = receiving end current  
 $\cos \phi_R$  = Receiving end pf.  
 $\cos \phi_S$  = Sending end pf.

Note: ① It is desirable that the voltage regulation of a transmission line should be less i.e. increase in load current should make very little difference in the receiving end voltage.

② It is desirable that efficiency of transmission line should be high for better performance.

### Performance of short Transmission Line.

As the distance is less in this line, the effect of capacitance is neglected in short transmission line. The effect of resistance & inductance are taken in account which are considered in lumped form at one side.

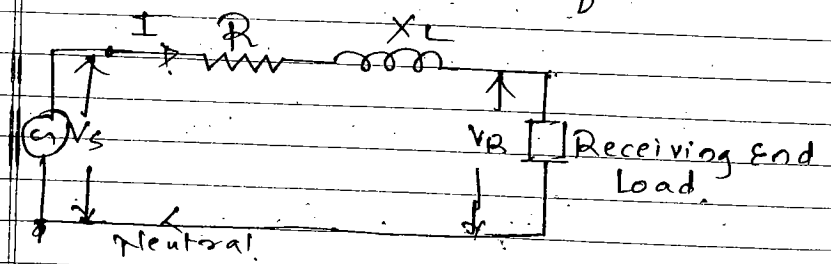

$V_S$  = sending end voltage/phase

$V_R$  = Receiving end voltage/phase

$I$  = Load current

$R$  = loop resistance (resistance in both)

$X_L =$  Loop reactance/phase.  
 $\cos \phi_R =$  Receiving end power factor (lagging)

$\cos \phi_S =$  Sending end power factor

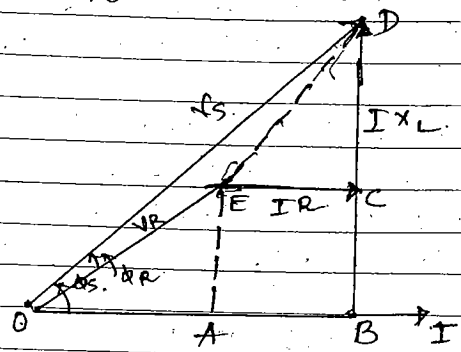

In vector diagram, current is taken as reference vector.

$\phi_R$  - phase angle at receiving end  
 $\phi_S$  - phase angle at sending end  
 $EC = IR =$  voltage drop due to resistance in phase with  $I$ .  
 $CD = IX_L =$  voltage drop due to reactance in quadrature with  $I$ .

From right angled  $\Delta OBD$   
 $(OD)^2 = (OB)^2 + (BD)^2$   
 $(OD)^2 = (OA + AB)^2 + (BC + CD)^2$   
 $V_S^2 = (V_R \cos \phi_R + IR)^2 + (V_R \sin \phi_R + IX_L)^2$

$$V_S = \sqrt{(V_R \cos \phi_R + IR)^2 + (V_R \sin \phi_R + IX_L)^2}$$

+ lagging pf  
- leading pf

i) %age voltage regulation =  $\frac{V_S - V_R}{V_R} \times 100$

ii) Sending end pf  $\cos \phi_S = \frac{OB}{OD}$   
 $= \frac{V_R \cos \phi_R + IR}{V_S}$

Sending end power = Line i/p =  $V_S I_S \cos \phi_S$   
 Receiving end power = Line o/p =  $V_R I_R \cos \phi_R$

iii) power delivered =  $V_R I_R \cos \phi_R$   
 line losses =  $I^2 R$   
 Power sent out =  $V_R I_R \cos \phi_R + I^2 R$

%age transmission  $\eta = \frac{\text{Power delivered}}{\text{Power sent out}} \times 100$   
 $= \frac{\text{Line output}}{\text{Line o/p} + \text{line losses}} \times 100$   
 $= \frac{V_R I_R \cos \phi_R}{V_R I_R \cos \phi_R + I^2 R} \times 100$



Problems on Short transmission line.

- ① A single ph transmission line delivered 250kW power at the end of 10km at 13200V at pf of 0.8 lag. The resistance of conductor is 0.32Ω/km & loop inductance is 0.35mH/km. find
- Sending end voltage. & pf
  - percentage voltage regulation
  - Transmission Efficiency.

$P = 250 \times 10^3 \text{ W}$   
 $l = 10 \text{ km}$   
 $V_R = 13200 \text{ V}$   
 $\text{pf} = 0.8$   
 $R = 0.32 \Omega/\text{km}$   
 $X_L = 0.35 \text{ mH}/\text{km}$

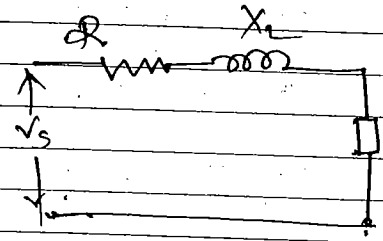

Resistance of each conductor =  $0.32 \Omega/\text{km}$   
 $\therefore$  Total loop resistance =  $2 \times 0.32 \times 10 = 6.4 \Omega$   
 Inductance =  $0.35 \text{ mH}$   
 Inductive reactance =  $2\pi fL$   
 $= 2 \times 50 \times 2\pi \times 0.35 \times 10^{-3}$   
 $= 1.099 \Omega$

current  $I = \frac{P}{V \cos \phi}$   
 $= \frac{250000}{13200 \times 0.8}$   
 $= 23.67 \text{ A}$

$\cos \phi_R = 0.8$   
 $\phi_R = \cos^{-1}(0.8) = 36.86^\circ$   
 $\sin \phi_R = \sin 36.86$   
 $= 0.6$

$$V_s = \sqrt{(V_R \cos \phi_R + IR)^2 + (V_R \sin \phi_R + IX_L)^2}$$

$$= \sqrt{(13200 \times 0.8 + 23.67 \times 6.4)^2 + (13200 \times 0.6 + 23.67 \times 1.099)^2}$$

$$= \sqrt{114735975.2 + 63139127.84}$$

$V_s = 13336.98 \text{ V}$

Sending end pf  $\cos \phi_s = \frac{V_R \cos \phi_R + IR}{V_s}$   
 $= \frac{13200 \times 0.8 + 23.67 \times 6.4}{13336.98}$   
 $= 0.803 \text{ lag}$   
 percentage voltage regulation =  $\frac{V_s - V_R}{V_R} \times 100$   
 $= \frac{13336.98 - 13200}{13200} \times 100$   
 Voltage Regulation =  $1.037\%$

Percentage transmission efficiency =  $\frac{V_R I_R \cos \phi_R}{V_s I_s \cos \phi_s + I^2 R} \times 100$   
 $= \frac{13200 \times 23.67 \times 0.8}{13200 \times 23.67 \times 0.8 + (23.67)^2 \times 6.4}$   
 $= 98.58\%$

- ② A load of 4MW at 1.1kV is being received from single ph transmission line at pf 0.9 lag. If resistance & reactance of each line is  $0.018 \Omega$  &  $0.02 \Omega$  respectively calculate.

- 1) Sending end voltage
- 2) Sending end pf & current
- 3) Voltage regulation of the line

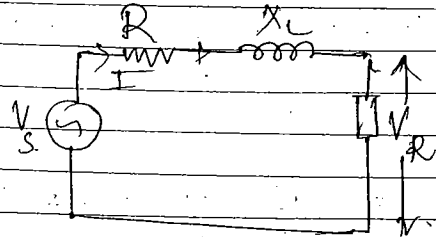

$$P = 4 \times 10^6 \text{ W}$$

$$V_R = 1100 \text{ V}$$

$$\cos \phi_R = 0.9$$

$$\text{Resistance of each conductor} = 0.018 \Omega$$

$$\text{Reactance of each line} = 0.02$$

$$\text{Loop resistance of line} = 2 \times 0.018 = 0.036 \Omega$$

$$\text{Loop reactance of the line} = X_L = 2 \times 0.02 = 0.04$$

$$\text{Load current } I = \frac{4 \times 10^6}{1100 \times 0.9}$$

$$I = 4040.4 \text{ A}$$

$$\cos \phi_R = 0.9 \quad \phi_R = \cos^{-1}(0.9) = 25.84^\circ$$

$$\sin \phi_R = \sin(25.84^\circ) = 0.435$$

$$V_s = \sqrt{(V_R \cos \phi_R + IR)^2 + (V_R \sin \phi_R + IX_L)^2}$$

$$= \sqrt{(1100 \times 0.9 + 4040.4 \times 0.036)^2 + (1100 \times 0.435 + 4040.4 \times 0.04)^2}$$

$$V_s = 1303.45 \text{ V}$$

$$\text{Sending end pf } \cos \phi_s = \frac{V_R \cos \phi_R + IR}{V_s}$$

$$\begin{aligned} \% \text{ Regulation} &= \frac{V_s - V_R}{V_R} \times 100 \\ &= \frac{1303.45 - 1100}{1100} \times 100 \\ &= 18.45\% \end{aligned}$$

- 2) Find length of single phase transmission line. The line delivers a power of 200 kW at 0.8 pf lag at the voltage of 2500 volts. The transmission line  $\eta$  is 89% & area of conductor used  $0.8 \text{ cm}^2$ . Take specific resistance of conductor material  $1.735 \mu\Omega/\text{cm}$

$$P = 200 \times 10^3 \text{ W}$$

$$V_R = 2500 \text{ V}$$

$$\cos \phi = 0.8 \text{ lag}$$

$$\eta = 89\% = 0.89$$

$$a = 0.8 \text{ cm}^2$$

$$\rho = 1.735 \times 10^{-6} \Omega/\text{cm}$$

$$I = \frac{P}{V \cos \phi} = \frac{200 \times 10^3}{2500 \times 0.8} = 100 \text{ A}$$

$$\text{Sending End Power} = \text{Receiving End Power}$$

$$= \frac{200 \times 10^3}{0.89}$$

$$= 224719.1 \text{ watts}$$

$$\text{Line losses} = \text{S/p - o/p}$$

$$= 224719.1 - 200000$$

$$= 24719.1 \text{ W}$$

If  $R$  is resistance of one conductor

$$\text{Losses} = 2I^2R$$

$$R = \frac{\text{Losses}}{2I^2}$$

$$= \frac{24719.1}{2(100)^2}$$

$$= 1.235 \Omega$$

$$R = \frac{\rho l}{a}$$

$$l = \frac{Ra}{\rho} = \frac{1.235 \times 0.8}{1.735 \times 10^{-6}}$$

$$= 569452.4 \text{ cm}$$

$$l = 5.69 \text{ km}$$

## Corona Formation

When an alternating potential difference is applied across two overhead transmission lines whose spacing is large enough compared to their diameters, there is no change in condition of atmospheric air surrounding the wires if voltage applied is low, if we gradually increase the voltage applied a/c the conductors a stage will arrive a faint luminous glow or violet colour will appear along with hissing sound, whether applied voltage is ac or dc phenomenon is observed called as corona.

Q Define corona & its formation.

The phenomenon of violet glow, hissing noise and production of ozone gas in an overhead transmission line is known as corona.

## Formation of Corona:

In the overhead transmission line natural atmospheric air acts as dielectric insulation. Due to ultraviolet radiations, cosmic rays, radioactivity etc almost always some ionisation is present in the air.

Hence under normal condition air contains some <sup>ion</sup> particles & neutral molecules.

When voltage is applied across the conductor, potential gradient is set up in air which is maxm at the surface of conductor.

Due to potential gradient, existing free electrons acquire greater velocities. When this potential gradient reaches maxm value about 30kV per cm, the velocity acquired by free electrons will be sufficient to strike a neutral molecule with enough force to dislodge one or more electrons from it. The phenomenon produces another ion or more electrons further produce ions & ionisation will be cumulative. Finally due to ionisation sparking occurs between two conductors which is nothing but formation of corona.

## List factors affecting corona.

1) Atmospheric conditions: The physical state of atmosphere, stormy whether the no of ions is more than normal hence corona occurs at much less voltage.

Factors based on atmospheric condition

i) No of ions ii) Charge & size/ion iii) Mean free path.

The no of ions charge & size per ion can be determined by electrical state of atmosphere, by atmospheric pollution. The mean free path can be controlled by the density of the air.

2) Based on physical condition of line

i) Voltage a/c the line  
ii) Ratio of distance to radius of conductor  
iii) State of conductor surface.

3) conductor size: Corona effect depends on shape & condition of conductors. The rough & irregular surface will give rise to more corona because unevenness of surface decreases breakdown voltage. Breakdown strength for stranded conductor will be less than smooth conductor ratio being 0.89 to 1. Dirt further reduces breakdown voltage.

4) Spacing b/w conductors: If spacing between conductors is much very large compared to their diameters, there may not be corona effect, larger distance between conductors reduces electrostatic stresses at conductor surface, thus avoiding corona formation.

~~★~~ List the advantages & disadvantages of corona.

Advantages:  
 i) Corona in a transmission line works as safety valve for surge.  
 ii) Corona in transmission line reduces transients produced by surges.  
 iii) Due to corona formation air surrounded by conductor becomes ionised effective diameter of conductor increases. This increased diameter of conductor reduces electrostatic stress b/w the two conductors.

Disadvantages:

- i) Corona is accompanied by loss of energy which affects transmission line efficiency.
- ii) Ozone is produced by corona & may cause corrosion of conductor due to chemical action.
- iii) The current drawn by the line due to corona is non sinusoidal & hence non sinusoidal voltage drop across line causing inductive interference with neighbouring communication lines.

~~★~~ Methods of Reducing Effects of corona.

While designing the line effect of corona plays very important role because due to corona flash over takes place b/w two conductors & over insulators. causes damage to equipments.

i) By increasing conductor size: (Critical disruptive voltage)  $V_{CD}$  the voltage at which corona occurs is raised by increasing conductor size & hence corona effects are considerably reduced. Hence ACSR conductors which have larger cross sectional area are used in transmission line.

ii) By increasing conductor spacing:  
 By increasing spacing b/w the conductors, the voltage at which corona occurs is raised hence corona effects can be eliminated. However spacing cant

Explain Skin Effect & Ferranti Effect

### Skin Effect

When a conductor is carrying steady direct current (dc), this current is uniformly distributed over the whole X section of the conductor. However an alternating current flowing through the conductor does not distribute uniformly, rather it has tendency to concentrate near the surface of conductor as shown in fig.

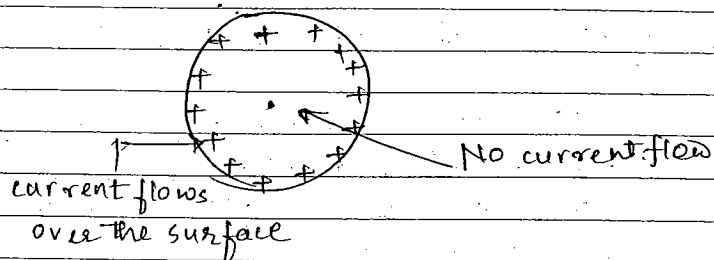

Define the tendency of alternating current to concentrate near the surface of a conductor is known as skin effect.

Effect: Due to skin effect, the effective area of cross section of conductor through which current flows is reduced. Consequently resistance of conductor is slightly increased. The skin effect is affected by

Ferranti Effect: ① Material type  
② shape of conductor ③ Diameter of conductor  
④ Frequency.

Skin effect can be reduced by using stranded conductor, where in uniform flux linkages is observed hence current distribution is also distributed uniformly.

### Ferranti Effect

Current flows from higher potential to lower potential, in transmission line the sending end voltage is higher than receiving end side. But, For medium & long transmission line if the transmission line have no load or lightly loaded then, the receiving end side voltage is higher than sending end side. This phenomena is called as Ferranti Effect.

### Why occurs?

A long transmission line is considered to be distributed with high amount of capacitor & inductor value over the entire line, the capacitors in long transmission line have huge amount of charging current, this charging ~~current~~ current leads to voltage drop across the line inductor which is in phase with sending end voltage, which increase at the receiving end side,  $\therefore$  voltage towards receiving end side is larger than source hence  $V_r > V_s$ .

This effect is negligible for short transmission line. since value of inductance & capacitance are neglected.

## Underground Cables.

The conductor coated with insulation is called cable. In highly populated area like metropolitan cities over-head transmission & distribution is impracticable and considered as hazardous. For safe transmission & distribution cables can be laid under the ground called underground cable system.

Underground cable system is employed for urban distribution system at low & comparatively moderate voltage.

## Classification of cables.

Cables are classified in different ways.

1) According to the number of conductors: It can be classified as

- i) Single core (conductor)
- ii) Two core
- iii) Three core or multicore.

2) According to the voltage rating: It can be classified as.

- a) Low voltage (LT) cables operating voltage upto 1kV.
- b) High voltage (HT) cables - operating voltage upto 11kV.
- c) Super tension (ST) cable: operating voltage 22 kV to 33 kV.
- d) Extra high tension (EHT) cables: operating voltage 33 kV to 66 kV.

- 4) According to methods of improving dielectric stress.
- a) Solid type cable
  - b) Oil filled cable
  - c) External oil pressure type cable.
  - d) Gas pressure type cable
  - e) Extra super tension (EST) cables. operating voltage 132 kV and above.

3) According to the nature of application of insulation and lead sheath.

- a) Belted type cable upto 11kV.
- b) Screened type cable.
  - i) H-type cable } from 22 kV - 66 kV.
  - ii) S-L type cable } (separate lead)
  - iii) H.S.L. (combination of H-type & S-L type cable)
- c) Pressure cables: for voltages beyond 66 kV

Explain construction of single core UG cable with diagram

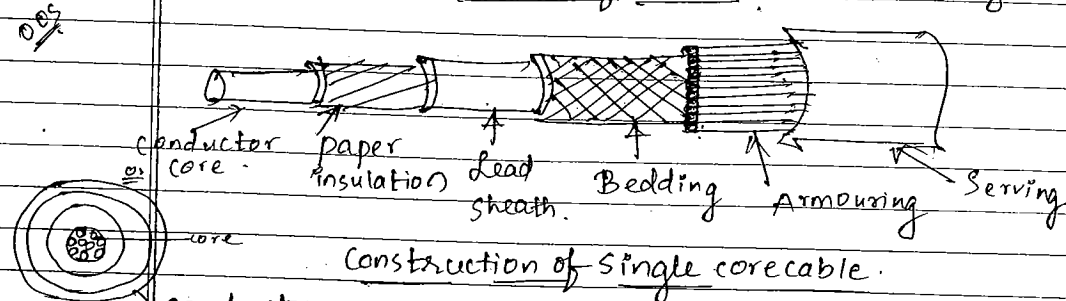

1) conductor or core: A cable may have one or more than one core depending upon the type of service for which it is intended. The conductor is placed at the centre and it is made up of tinned copper or aluminium. The conductor is stranded to get better flexibility.

2) Insulation: Each core or conductor is coated with insulation of impregnated paper

The thickness of this insulation depends upon voltage rating.

Lead sheath: A metallic sheath of lead or aluminium is provided over the paper insulation. The sheath protects the cable from moisture, gases or damaging liquids like acids or alkalis.

Bedding: Bedding is the layer provided over lead sheath. It consists of fibrous material like jute or hessian type. The bedding is provided in a cable to protect lead sheath against corrosion & mechanical injury.

Armouring: Armouring is layer of galvanized steel wire or tape, which protects cable from mechanical injury during laying & handling.

Serving: Serving is a layer of fibrous material like jute similar to that of bedding provided over armouring, which protects from atmospheric conditions.

Properties of Insulating material used for cables

The insulating material used for UG cables must have following properties.

- 1) High insulation resistance: To avoid leakage current, resistance of the insulation should be high.

- 2) High dielectric strength: To avoid electric breakdown the dielectric strength of insulation should be high.

- 3) High mechanical strength: To withstand against mechanical handling the cable should have high mechanical strength.

- 4) Non hygroscopic: The insulation should not absorb moisture from air and soil because moisture reduces insulating properties. When a dielectric material used is hygroscopic then it should be enclosed in a waterproof covering like lead sheath.

- 5) Unaffected from acid alkalis: The insulation used should be able to withstand effects of acids & alkalis i.e. it should not form any chemical compound with acid & alkalis.

- 6) The insulation should be non inflammable.

- 7) It should have low permittivity.

- 8) It should have low thermal coefficient.

- 9) The insulation must be cheap.

No single material has all above mentioned properties. The general material used for cable are

- 1) Rubber
- 2) Vulcanised India Rubber (VIR)
- 3) Polyvinyl chloride
- 4) Varnished Cambre.
- 5) Impregnated paper.



Construction of single core UG cable.

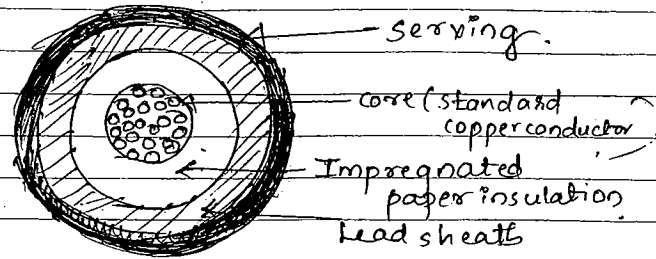

- ⇒ This cable consists of one circular core of tinned stranded aluminium or copper conductor, insulated by layers of impregnated paper or varnished cambr.
- ⇒ To protect the cables from moisture & mechanical handling, lead sheathing is provided over the insulated paper.
- ⇒ To protect lead sheath from corrosion serving of compounded material is provided over the lead sheath.
- ⇒ The single core low voltage cable is not generally armoured in order to avoid excessive sheath loss.
- ⇒ The cable is designed for low voltage capacity, hence electrostatic stresses developed are small & thermal conductivity is of no importance.

XLPE Cables:

XLPE stands for cross linked polyethylene. cross linked polyethylene is produced from polyethylene under high pressure with organic peroxides as additives. These have strong resistance to deformation even at high temperatures.

The application of heat & pressure is used to effect the cross linking which causes individual molecular chains to link with one another which in turn causes material from thermoplastic to elastic.

An important advantage of XLPE as insulation for medium & high voltage cables is their low dielectric loss, reducing charging currents and earth leakage currents.

Construction of Three Core XLPE Insulated unarmoured PVC Sheathed cable:  
 for voltages 6.6 kV upto including 33 kV

Q: Explain with diagram construction of XLPE cable.

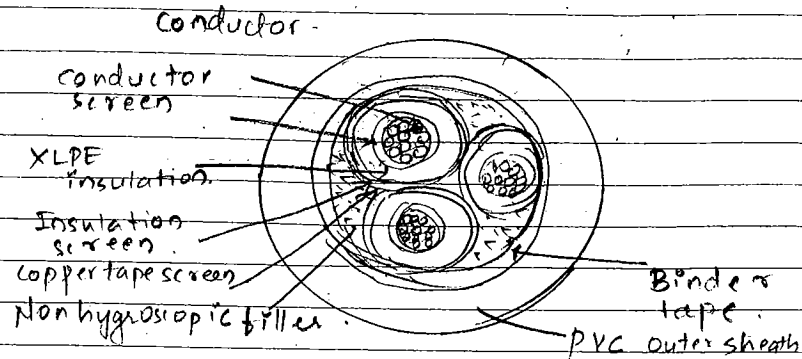

Applications: These cables are generally suitable for direct burial or for installation on trays or ducts where there is risk of mechanical damage armoured cables should be used.

The cable can be described as circular compacted stranded copper or aluminium conductor, XLPE insulated copper tape screened, three core assembled together with non-hygroscopic polypropylene filler & extruded with PVC outer sheath.

The cable can be described as circular compacted copper conductor XLPE insulated copper tape screened 3 core

Conductor - The conductor of cable consists of 3 cores/conductors made up of plain circular compacted stranded copper or aluminium. The conductor screen is an extruded layer of semiconductive compound.

2) Insulation: The insulation placed over the conductor is made of XLPE cross linked polyethylene which is sated at 90°C. The insulation screen is nonmetallic comprised of

- i) Non metallic part - Extruded layer of semiconductive compound.
  - ii) Metallic part - copper tape screen (scr)
- Non hygroscopic polypropylene filler material is used for insulation.

Assembly: The three screened cores are laid up together, if necessary filled with non-hygroscopic material compatible with insulation & covered with a layer of PVC sheath. The outer sheath are of PVC types.

XLPE Armoured Cable

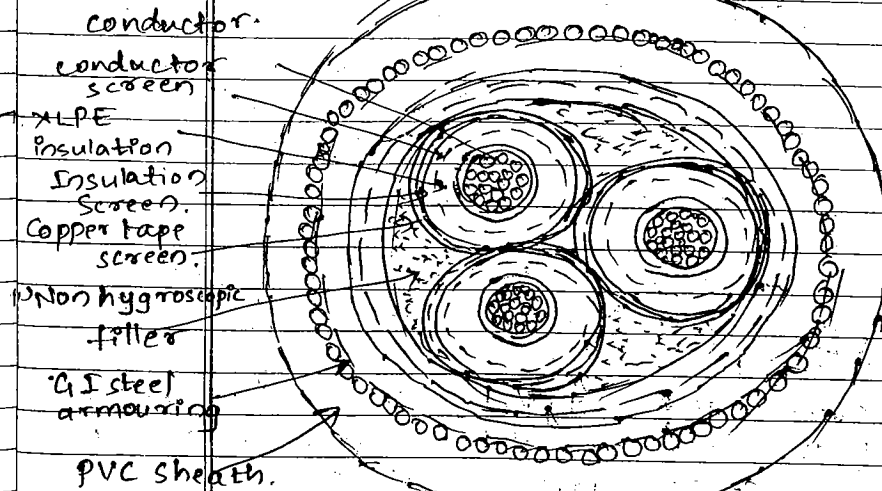

[Same as unarmoured. other explanation]  
Bedding: Extruded layer of PVC ST2 compound  
Armour: Galvanized steel wires shall be applied helically over the PVC bedding  
outer sheath: PVC types.

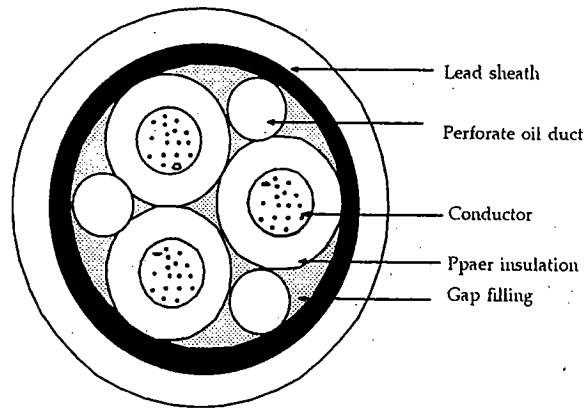

Fig. 3.9 3-core filler-spaced channel type oil-filled cable

**Disadvantages of Oil filled cable over the solid cable :**

- 1) The laying of cable is complicated.
- 2) The cost of cable will be high.
- 3) High maintenance.

**b) Gas Filled cable or gas pressure cable :**

If the ordinary cable is subjected to high pressure, the ionisation can be altogether eliminated. In these cables pressure is applied externally, as the pressure increases the voltage at which the ionisation start increases. If the pressure is increased to about 12 atmospheres the ionisation totally disappears at the same time working power factor of the cable is improved.

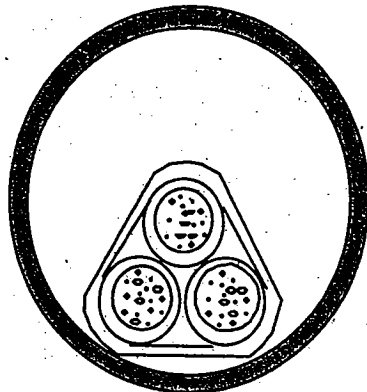

Fig. 3.10 Gas pressure cable.

The pressure cable was designed by Hockstadter, Vogel and Bowden. Fig. 3.10 shows cross-section of such cable. The general construction of this cable is similar to that of solid cable except that its shape is triangular and the thickness of lead sheath is 75% that of solid cable. Here the lead sheath acts as a pressure member and the triangular section reduces weight. In this construction of cable sheath is protected by a thin metal tape. The entire cable is laid in a gas-tight steel conduit. The steel conduit is filled with dry nitrogen gas at 12 to 15 atmospheres which continuously compresses the cable radially from outside hence radial breathing of the cable occurs and voids are closed. The steel pipe is coated with a paint to protect against corrosion.

**Advantages of Gas Pressure Cables :**

- 1) Maintenance required is less.
- 2) The nitrogen helps in quenching any flame.
- 3) Laying of cable will be ideal.
- 4) These cables carries 1.4 to 1.6 times load current than ordinary cable.
- 5) Such cables can be operated at higher voltage i.e., double the ordinary cable voltage.
- 6) Power transmitted by this cable is 2.4 to 3.2 times more than ordinary cable.

**Disadvantage of Gas Pressure Cable :** a) The overall cost is very high.

**3.6 Laying of under ground cables :**

There are three methods of laying cables namely.

- 1) Direct laying system
- 2) Draw in system
- 3) Solid system.

**1) Direct laying system :** In direct laying system of cable laying a trench of around 1.5 m deep and 45 cm wide is dug in the ground along the route of laying. The bottom the trench is covered with a layer of fine sand at about 10 cm thick called sand bed. The cable is directly laid over this sand. The fine sand protect cable from entry of moisture and decay. Above the cable another layer of fine sand is provided of about 10 cm thickness. To protect the cable against mechanical injury it is covered with bricks or concrete slab or tiles. If single trench carries more than one cable then there is chances of mutual heating and fault occurs in one cable can damage the other cable. Hence spacing of 30 cm is provided both vertical and horizontal between two cables.

The direct laying is laid with bare, sheath without armouring or with a serving of bituminised paper and hessian over the sheath. If the soil contains harmful chemicals, the serving must be adequate to protect the cable from corrosion and electrolysis. Fig. 3.11 shows direct laying system of cable.

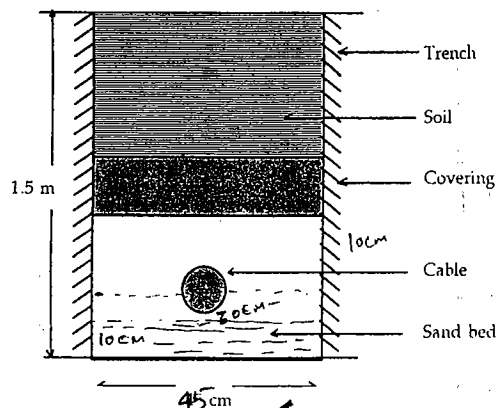

Fig. 3.11 Direct laying system

**Advantages of direct laying system :**

- 1) It is the simplest and cheapest method.
- 2) It is the safe method and free from the external disturbance like traffic variations etc.
- 3) This method gives best conditions for dissipating the heat generated in the cables.

**Disadvantages of direct laying system :**

- 1) The maintenance cost is very high.
- 2) The fault location is difficult.
- 3) The alteration work is difficult.
- 4) The load extension is possible only by new excavation which is more costly.

**2) Draw in system:** In this system of laying duct or conduit of cast iron or concrete or glazed stone are laid along the route of cable. In between these conduit man holes are made. From the manholes cables are pulled into conduit during installation and repair. Fig. 3.12 shows section of draw in system for four cables. According to the requirements the system can be of single duct or multiduct. This method of cable laying is used in the cities and areas where excavation is expensive and inconvenient. This method is generally used for small distance of laying, like road crossing, workshop etc. Where once the conduits have been laid, repair and alteration can be easily done through manholes without opening the ground. The span between the manholes should not be too long to make pulling of cable easier. The cable used in this system need not be armoured but it must be provided with serving.

**Disadvantages of solid system**

- ① It is more expensive than direct laid system.
- ② It requires skilled labours & favourable weather conditions
- ③ Due to poor heat dissipation, current carrying capacity

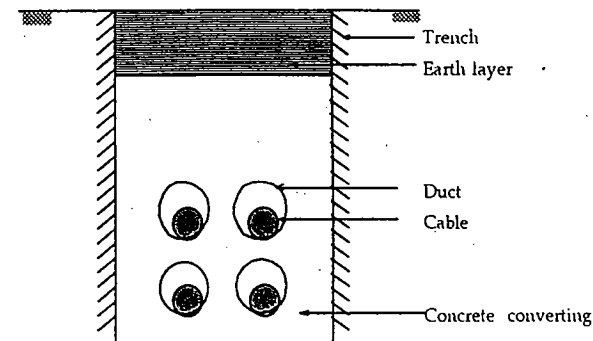

Fig. 3.12 Draw-in-system.

**Advantages of Draw-in-system of laying :**

- 1) Repairing and maintenance can be easily done without opening the ground.
- 2) Addition and alteration is possible.
- 3) Jointing of cables are easy because of unarmoured.
- 4) Less chances of fault occurrence.
- 5) System is mechanically strong.

**Disadvantages of Draw-In-system of laying :**

- 1) The current carrying capacity of cable will be reduced because of close grouping of cables.
- 2) The initial cost of system is very high.

**3) Solid system :** In this system of cable laying, cable is laid in a throughs or open pipe placed in earth along the cable route. The throughs is made up of treated wood or stone core or cast iron. After laying the cable throughing the filled with asphalt or bituminous and then covered. This method of laying cable is rarely used now a days as it is more expensive and it requires skilled labour. The current capacity of cable in this system is less, due to poor heat dissipation facilities. Fig. 3.13 show section of solid system of cable laying. Cables laid in this manner are usually, plain lead covered, as the throughing affords good mechanical protection.

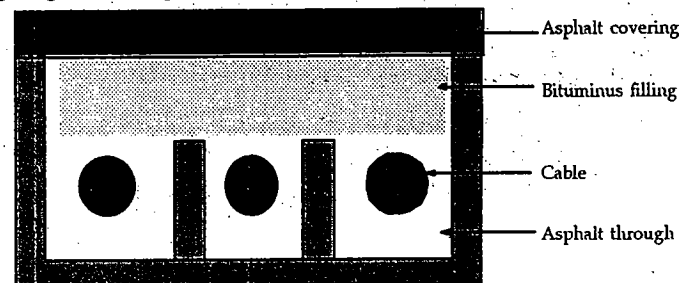

Fig.3.13 Solid system using Asphalt through.

**Fill in the blanks :**

- 1) High tension cables in power transmission can be used only up to voltage of \_\_\_\_\_ (33KV)
- 2) Protection against external injuries to underground cable is provided by \_\_\_\_\_. (armouring)
- 3) The entry of moisture in to the insulation of cable is prevented by \_\_\_\_\_. (Metallic sheath)
- 4) In underground cable around the core \_\_\_\_\_ is provided for protecting main insulation. (bedding)
- 5) The over head system is \_\_\_\_\_ than underground system. (cheaper)
- 6) To avoid excessive sheath loss \_\_\_\_\_ is not done in single core cable. (armouring)
- 7) Up to \_\_\_\_\_ voltage belted cables are used. (11 KV)
- 8) Insulation resistance is \_\_\_\_\_ proportional to the length of cable. (inversly)
- 9) For HV cable the most common insulation is \_\_\_\_\_. (impregnated paper)
- 10) Voltage drop in cable system is \_\_\_\_\_ than over head system. (less)
- 11) Voids in paper insulation decreases \_\_\_\_\_ of cable. (break down voltage)
- 12) For above 66KV \_\_\_\_\_ cables are used. (oil filled)
- 13) SF<sub>6</sub> cables are insulated by \_\_\_\_\_. ((high pressure oil)
- 14) Conductor plus \_\_\_\_\_ together is called cable. (insulation)
- 15) Charging current in under ground cable system is \_\_\_\_\_ due to high capacitance. (high)
- 16) Underground system cannot be used for \_\_\_\_\_. (very high voltage)
- 17) In oil filled cable the thickness of insulation required will be \_\_\_\_\_. (less)
- 18) S:L. type cable is used up to the working voltage of \_\_\_\_\_. (66 KV)
- 19) Cable below 1 KV comes under \_\_\_\_\_. (low voltage)
- 20) The primitivity and thermal co-efficient of cable insulation should be \_\_\_\_\_. (low)

**Review Questions :**

- 1) What are the advantages and disadvantages of under ground cables?
- 2) Compare UGC and over head system.
- 3) What are the properties that insulation materials used for cables should have?
- 4) Explain with figure construction of cable.
- 5) How the under ground cables are classified ?
- 6) Explain with neat sketch a) H type cable b) S L type cable.
- 7) What are oil filled and pressure cables ?
- 8) What are the advantages and disadvantages of oil filled cables ?
- 9) Explain with neat sketch gas pressure cable.
- 10) Explain with sketch systems for laying the cable.

## Erection and Maintenance of Transmission Lines

**4.1 Materials used or Main Components of Transmission lines and Distribution :**

The main components of overhead transmission and distribution lines are :

1. **Supports :** Depending upon voltage rating of the line supports may be poles or towers which keep the conductor at a suitable height above the ground.
2. **Conductors :** Depending upon magnitude of current and span between the two supports the conductors may be of copper, aluminium or ACSR which carry electric power from one end to the another end.
3. **Insulators :** Insulators are attached to the supports and insulate the conductor from ground.
4. **Cross arms :** Cross arms supports to the insulators etc.
5. **Miscellaneous items :** Guy sets, jumper loops, anticlimbing device, phase plates, danger plates, bird gaurds etc.

**Supports :** The supporting structures used for overhead transmission and distribution poles and towers. For voltage below 66 KV poles are used and for 66 KV and above steel fabricated lattice towers are used.

**Requirements of line supports :**

1. They should have high mechanical strength to stand against weight of conductors, wind pressure etc.
2. Cheap in cost,                      3. Light in weight.
4. Longer life                              5. Low maintainance cost.
6. Immune to damage for lightning and fire.
7. Easily accessible for painting and erection of line conductors.

List the types of cable faults:

Following are the types of cable faults commonly found in the UG cables.

① Open circuit: Open circuit fault is a kind of fault that occurs as a result of conductor breaking or conductor being pulled out of its joint. There will be no current flow at all as conductor is broken.

② Short circuit or cross fault: when the insulation between two cables or between two multicore cables gets damaged.

In such instances current will not flow through the main core which is connected to load but will flow directly from one cable to another or from one core to other or multicore instead the load will be short circuited.

Ground or Earth fault: This kind of fault occurs when the insulation of the cable gets damaged. The current flowing through the faulty cable starts flowing from core of cable to earth or the sheath of the cable.

Intro.

Transposition of overhead line conductors  
[The most common used system for overhead transmission is 3ph 3wire becoz, it is more convenient to be placed on poles or towers, along with this in 3ph 3wire system we can keep average height above the ground of conductors as low as possible in order to minimise accident & hazards due to lightning]

\* When the conductors of 3ph overhead system are unsymmetrically spaced, then the constants i.e inductance & capacitance are not the same in the different phases. Due to interchange of power between the phases there is wide difference in the resistance of conductor.

As the constants of three lines are not equal, the voltage drop i.e  $IZ$  will be different in each line, which may result unbalanced voltage at receiving end even if sending end voltage is balanced. Therefore practically such lines are interchange at particular distance called transposition of conductor.

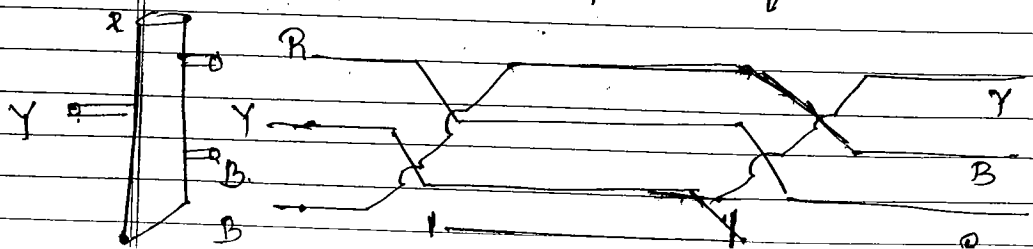

The designed length between two points where conductor terminals are transposed is called a span.

Inductance & capacitance of transposed lines.

Generally overhead line conductors are transposed when they are irregularly spaced. In 3ph system, for mathematical calculation it is considered that conductors are spaced symmetrically at an equivalent spacing

$$D = \sqrt[3]{D_1 D_2 D_3}$$

$D_1, D_2, D_3$  are spacing b/w conductors.

$D =$  Geometrical mean distance.

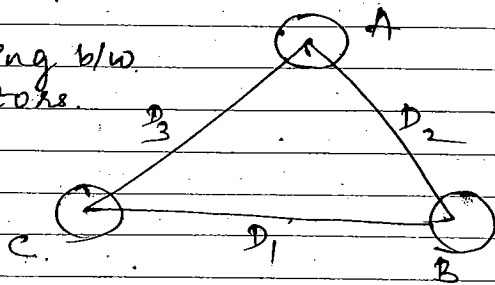

The value of inductance

$L$  / conductor / km. =

$$L = \left[ 0.5 + 2 \log_e \frac{\sqrt[3]{D_1 D_2 D_3}}{r} \right] \times 10^{-4} \text{ henry}$$

capacitance / conductor / km =  $C$

$$C = \frac{0.0556}{\log \frac{\sqrt[3]{D_1 D_2 D_3}}{r}} \text{ } \mu\text{f} / \text{km}$$

## Substations

Normally large power generating stations are built far away from the load centres, there are a number of transformations and switching stations which are built in b/w generating stations & to the customer, which are known as substations.

A typical substation consisting of transformers, circuit breakers, disconnecting switches, station bays, insulators, reactors, capacitors, CT & PT's, grounding slm, LA & spark gaps, wave traps, protective relay, station batteries etc.

### \* Types of Substations

depending on the purpose, the substations may be classified into five categories.

#### ① Generating Substations or Step up Substations:-

In generating substation, the generating voltages are limited and need to be stepped up to transmission voltage therefore large amount of power generation is to be transmitted over long period, in large amount.

Each generating unit is connected to the generating transformer to increase the secondary voltage up to transmission voltage level.

\* Grid Substations :- These substations are located in the intermediate points b/w the generating stations & load centres. The main purpose of these substations are to provide connections of low voltage lines, some compensating devices etc.

\* Secondary Substations :- Secondary substations are connected with main grid substation with the help of secondary



secondary transmission line. The voltage at these substation is stepped down to the transmission voltage. Some of the large consumers are also connected to these substations.

\* distribution substations :- These substation is located where subtransmission voltage is to be stepped down to the supply voltage. These substations feed power to the actual consumers through distributors & service wire.

\* Special purpose substations :- These substations are specified for some special applications such as for bulk power transmission & supply of industrial loads.

for example → Traction substation & mining substation.

However some special considerations are required in these substations such as load distribution in phases in traction substation & safety precautions in the mining substation.

\* depending on physical feature the substations are also classified as follows.

① outdoor type    ② indoor type    ③ pole mounted  
④ underground type

\* outdoor type :- Normally outdoor substations are used for 33-kV voltage and above for cost and safety reasons. The air clearance required is more.

All the equipments are open in the air & control and monitoring is performed inside the control room.

\* Indoor type :- The equipments of this substation are in a room. The operating voltages are normally 400V &

11kV. The substations are usually located in big cities.

\* pole mounted or open type :- as the name indicates these substations are mounted on pole, they are very simple and cheap, as there is no building for housing the equipments are required. these substations are having very low capacity 500-kVA transformer.

\* underground type :- these substations are used when space is not available. whole substation is made underground. The size of the substation can be high or low depending upon the capacity.

usually the design of substation aims to achieve a high degree of continuity, maximum reliability and flexibility, to meet these objectives with the highest possible economy.

### \* Location of Substation

Location of distribution substation depends on the several factors such as voltage level, voltage regulation considerations, subtransmission costs, substation costs, & the cost of primary feeders, mains & distribution transformer.

Some non-technical factors such as availability of land, public safety etc. are also important. as far as the industrial and commercial substations are concerned, they are normally located near to or within the premises of the consumer.

\* to select ideal location for a distribution substation, following rules are to be considered →

- ① Locate the substation as much as close to the load centre of its service area.
  - ② Locate the substation such that proper voltage regulation can be obtained without taking extensive measures.
  - ③ Select the substation location such that it provides proper access for incoming subtransmission line and outgoing primary feeders and also capable to handle the future expansion.
  - ④ Selected location should be in accordance with the the electricity rule and land use regulation.
  - ⑤ The selected substation should help to minimize the number of customers affected by any service discontinuity.
-

\* Bus bar arrangement Schemes.

The choice of bus scheme depends on the relative importance assigned to such items as safety, reliability, voltage level, simplicity of relay, flexibility of operation, cost, maintenance, available ground area, location of connecting lines, provision of expansion.

\* Single Bus Scheme

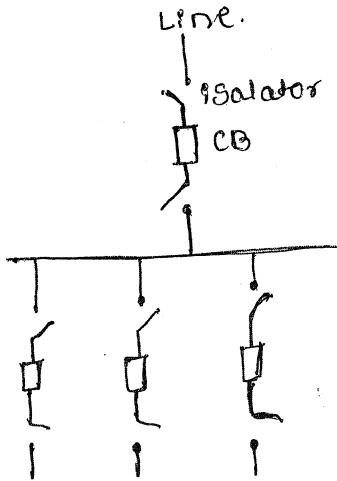

fig - Single bus scheme.

Above fig shows typical

single bus scheme for voltage of 33kV or lower & has a simple design.

\* It is used in small outdoor substations with few no of outgoing or incoming feeders and lines.

\* The main advantage is its cost is low.

at the same time it has several disadvantages they are as follows. (1) Dependency on a single bus may cause serious outage during the bus failure.

(2) difficulty to do any type of maintenance work.

(3) Bus can't be extended without completely de-energizing the substation.

(4) It can be used only where load can be interrupted.

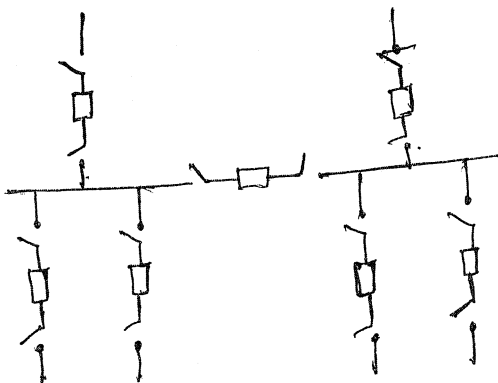
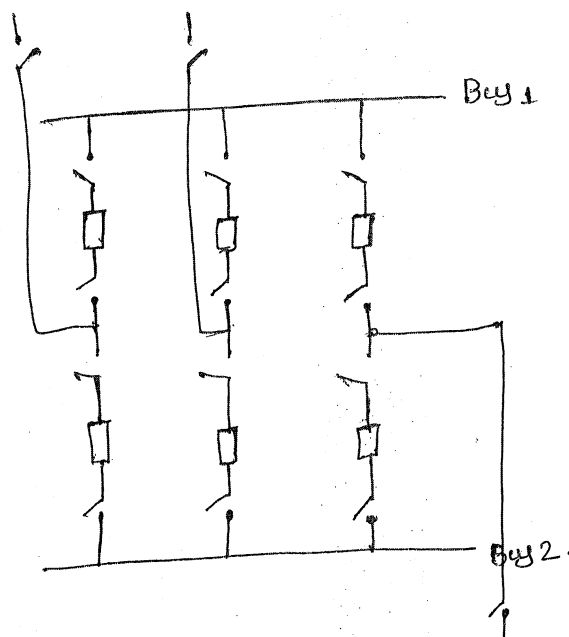

fig b) Single bus scheme with bus sectionalizer.

As shown in the above fig, In single-bus bar scheme with sectionalizer, in which bus bar is normally divided into two sections, with the help of breaker & isolator.

\* The incoming & outgoing circuits are evenly distributed each section will act as a separate bus bar.

\* double bus with double breaker



Such type of schemes are much more useful in most of the purpose. addition of load as well continuity supply increases the cost. The main advantages are:-

- a) Each circuit has two dedicated breakers.
- b) Any breaker can be taken out for maintenance.
- c) It is more reliable than single bus scheme.
- d) It is much more flexible.

\* double bus with single breaker

As shown below this scheme uses two main buses & connected with two disconnecting switches → a bus tie-CB or bus coupler is used as it enables

a load change over from one bus to other.

the advantages are

- ① It permits some flexibility with two operating buses
- ② either bus 1 or bus 2 can be isolated for maintenance
- ③ circuit can be transferred by the use of the breaker & isolator.

\*disadvantages are

- a) an extra breaker is required
- b) four isolators are required per circuit.
- c) Bus tie-breaker fault takes entire substation out of service.
- d) It will not permit maintenance without stopping supply

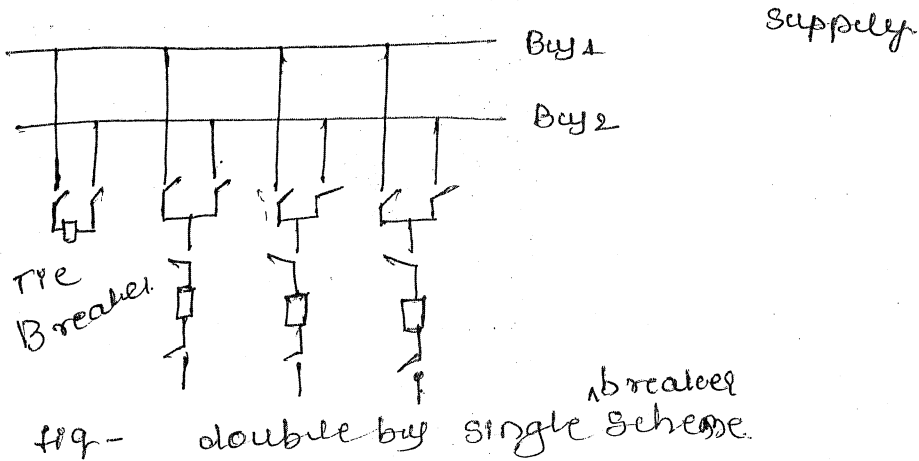

\* Main & transfer Bus.

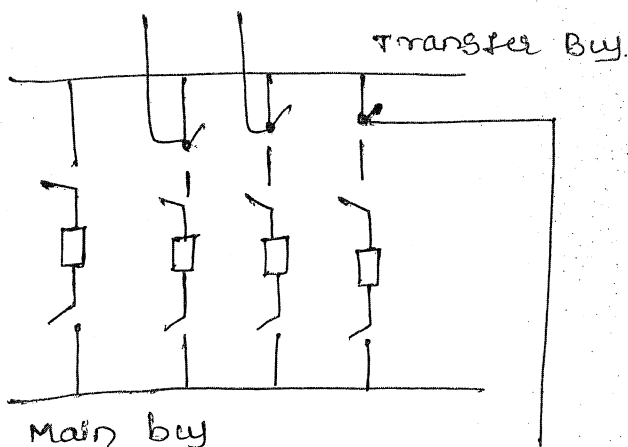

fig - Main bus & transfer Bus.

The above fig shows main & transfer bus, which is more commonly used in distribution substation.

In this scheme several circuit breakers are saved, however one extra breaker is provided to tie the main and transfer bus.

\* the main advantage of this scheme is its initial cost is low, & ultimate cost is also low.

\* any breaker can be taken out of service for maintenance and potential device may be used on the main bus for relaying.

\* The main drawback of the STM is - Switching is some what complicated when maintaining a breaker, failure of bus, or any of CB results in complete shut down of entire substation. & it may addition of circuit breakers.

### \* Ring Bus

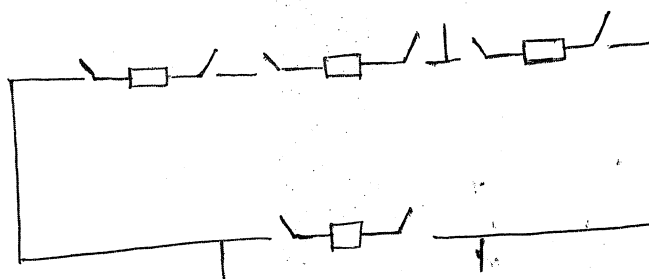

fig - Ring bus or mesh scheme

### \* disadvantage

- ① Automatic reclosing & protective relaying circuitry is complex
- ② during fault clearance ring is divided into two sections.

The scheme is also known as mesh scheme, it requires

- only one CB per circuit. The advantages of the scheme are →
- ① low initial cost
  - ② flexible operation for breaker maintenance
  - ③ any breaker can be taken out for maintenance purpose without interrupting load.
  - ④ it does not use main bus
  - ⑤ each circuit is fed by two breakers
  - ⑥ all switching is done through breaker.

\* Breaker and a Half with two main Buses

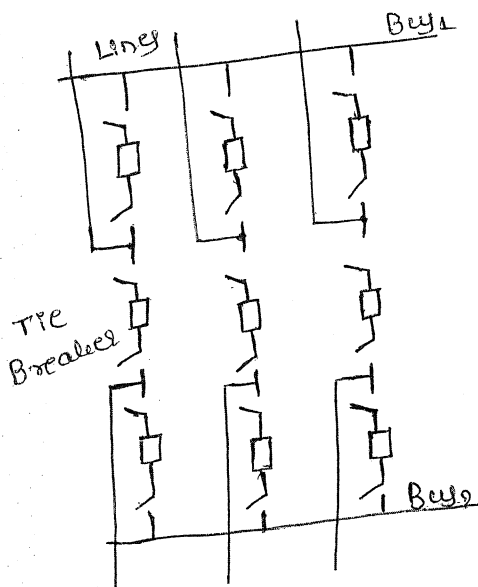

fig - Breaker & a half scheme

It is an improvement double-bus, double-breaker scheme to save the cost of breakers. As shown above

three breakers are used in serving both the main buses.

\* Under normal operating condition all the breakers are closed & the main buses are energized.

\* To trip a circuit, two associated CBs must be opened. The disadvantage of the scheme is complicated protection.

\* Advantages

- ① Most flexible operation.
- ② High reliability
- ③ All switching is done with breakers
- ④ either main bus can be taken out of service with supply interruption.
- ⑤ Bus failure does not remove any feeder circuit from service.
- ⑥ Simple operation & no disconnect switching required for normal operation.



## \* Double bus-bar with Bypass Isolators

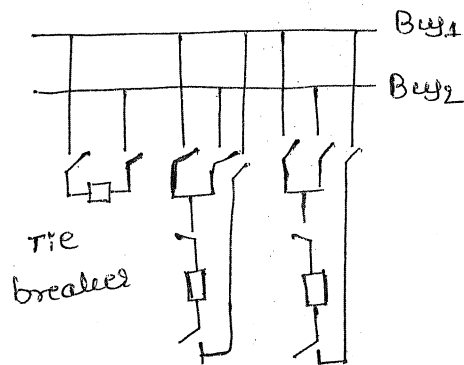

fig - double bus with bypass isolator.

This is a scheme similar to main & transfer bus out of both bus any bus can act as main bus & other bus will act as transfer bus.

\* The main advantage of the scheme is any breaker can be taken out of service without interrupting the supply of any feeder. The scheme is very simple & economical.

\* Grounding :- A proper grounding is must required for safe and reliable operation of the substation.

\* all power systems will operate with grounded neutral.

\* The neutral earthing is one of the most important feature in substation design.

\* due to defective electrical apparatus & some other reasons, electricity causes electric shock hazards for human being and animals.  $\therefore$  it is a common practice to connect electric supply line to ground at suitable points.

\* Grounding is a measure taken to increase the reliability of supply service, as it provides stability of voltage conditions, prevents excessive voltage peaks during the disturbance.

\* Resistance Grounding.

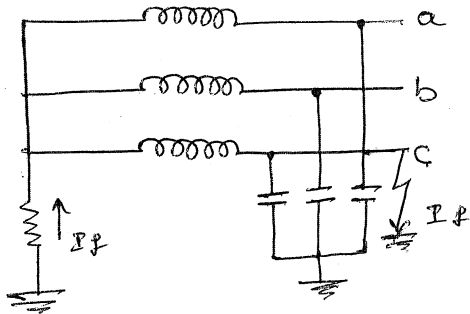

Fig - Resistance grounding.

For the voltage level b/w 3.3kV & 22kV, the ground c/n is not large to use reactance grounding.

\* The ground fault c/n, for solid grounding become very high. ~~high~~ ∴ the neutral point is connected with resistance which is known as resistance grounding.

\* To limit the fault c/n high resistance is used which save the power loss & improves the stability of the s/m during the fault.

\* For the ckt below 3.3kV, there is no need of external resistance because the earth fault c/n can be limited due to inherent ground resistance i.e. 1.5ohm.

\* In resistance grounding s/m, the power loss during the line to ground fault is the main consideration.

\* Normally resistor value is given by  $R = \frac{V_{LL}}{\sqrt{3}I_f}$ .

\* interconnection of substations.

Where  $I$  is the full load c/n of largest m/c in amperes.

\* Peterson gave the formula for resistor

$$R = (2.0 \text{ to } 1.25) \frac{1}{\text{cat}^2 \text{c.c.}}$$

Where  $c_a, c_b, c_c$  are capacitances of each phase to earth.

\* Reactance Grounding.

Between the voltage 3.3 kV and 22 kV, the solid grounding is not used due to excessive fault c/n &  $\therefore$  resistance & reactance grounding must be used.

To limit the fault c/n resistance is popular in UK, whereas reactance is popular in Europe.

\* The reactance connected b/w neutral & ground provides the lagging c/n which neutralize the capacitive c/n.

\* there is no rule for use of either resistance or reactance.

\* whenever charging c/n is high, such as for cables, EHV & long capacitors etc the reactance grounding is used. otherwise resistance grounding is preferred.

\* The grounding of solid & reactance is decided by following relation for solid grounded s/n  $X_0/X_1 \leq 3.0$

91/5/17 \* 12, 15, 101, 15  
- 3, 5, 6, 17, 24, 30, 33, 35, 44, 45, 51, 52, 64, 69.

10/5/17 - 7, 12, 14, 15, 17, 19, 20, 24, 25, 27, 34, 50, 51, 53, 56, 64, 68,

## \* Introduction to Substation equipments

A Substation has several equipments:- transformers, circuit breakers, disconnecting switches, fuses, station buses, insulators, reactors, current & potential transformers, grounding s/m, lightning arrestors, gaps, line traps, protective relay, station battery etc.

\* protective relay:- A protective relay is a type of protective device, which gives an alarm signal or to cause prompt removal of any element from service when the element behaves abnormally.

The functions of protective relay are

① The removal of component which is behaving abnormally by closing the trip circuit of circuit breaker or to sound an alarm.

② In order to disconnect the abnormally operating part to avoid damage or interference effective operation of ~~the~~ rest of the system.

③ To prevent the subsequent faults by disconnecting the abnormally operating part.

④ relays are helpful to disconnect the faulty part as early as possible to minimize the damage to the faulty part of the s/m itself.

⑤ to improve the s/m performance, s/m reliability, s/m stability & service continuity the relays are helpful.

\* Circuit Breaker:- Circuit Breaker normally gets the signal from protective relays to operate, is an automatic switch which can interrupt the fault current. circuit breaker consists of two contacts one is fixed contact & other is moving contact. under normal operating condition both the contacts of CB are fixed, during abnormal running condition the arc is gets introduced b/w the contacts of CB & it trip to separate faulty & unhealthy part of power system.

The circuit breakers are classified on the basis of rated voltage such as low-voltage CB & high voltage CB. Based on the medium of arc extinction, the circuit breakers are also classified as follows.

- a) Air break circuit breaker (used upto 12kV) & miniature circuit breaker (up to 600V), & air is considered at the atmospheric pressure.
  - b) oil circuit breaker
  - c) Minimum oil circuit breaker (for 3.6-245kV)
  - d) Air blast circuit breaker (for 245-1100kV) where compressed air is used.
  - e) SF<sub>6</sub> circuit breaker (for 36-420kV) where SF<sub>6</sub> gas is used.
  - f) Vacuum circuit breaker (up to 36kV) where vacuum is used as arc quenching medium.
- ⇒ Based on the mode of arc extinction, circuit breakers can be classified as high-resistance interruption circuit breaker & low resistance (zero point interruption) CB.

The circuit breakers are decided based on voltage & fault current of the place where it is to installed.

The voltage rating of circuit Breaker is normally from 1.05 to 1.10 times more than the normal operating voltage. For example if the rating of CB is 400kV would be 420kV.

Most of the EHV circuit breakers are provided with auto reclosure.

#### \* Reactors and capacitors:-

To limit the line charging c/n, long distance EHV lines are connected with line reactors at both the ends, These reactors are permanently connected to the line.

\* Beside these, there are bay reactors & tertiary reactors which are connected with switches. These are used during light-loading conditions and at the line charging.

\* Bay reactors are connected at the substation bay, where a tertiary reactors are connected in the tertiary winding of the transformer.

By using these reactors Ferranti effect is reduced.

\* Capacitors are normally connected in low-voltage systems during peak-load conditions, the system voltage falls & therefore capacitive reactive power is required.

\* In EHV system, it is preferred to use static VAR system because it takes care of reactive power which can supply both leading and lagging reactive power.

\* In distribution system or in sub-transmission system, capacitors are connected to improve the power factor of the system.

\* Lightning arrester:- It is also known as surge arrester normally connected b/w the phase and ground at

at the substation, lightning arrester is used to protect the substation equipments due to lightning and switching surges.

\* Surge arrestors offer low resistance to the high voltage surge for diverting to the ground.

\* after discharging the surge energy to ground, it blocks the normal current flowing to ground by providing high resistance path.

\* Isolators & fuses :- An isolator operates under no-load condition [high voltage disconnect switch] and does not have any cin breaking & making capacity & it is used for disconnecting the CB from live part.

Isolators are used in addition to CBS which can make & break the circuit under normal & short circuit conditions.

\* for opening a circuit, the CB is opened 1st & then Isolator is operated.

\* In addition to Isolator & circuit breaker, another device known as load break switch combining the function of Isolator and switch.

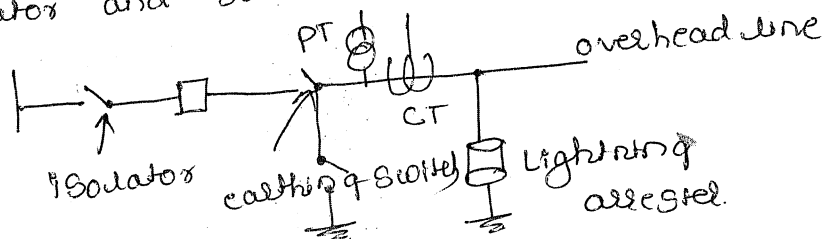

Fig - Isolator position

A fuse is a simple protective device, used for protection of excessive currents due to overload or fault. They are normally used up to 600V installations. HRC fuses are more reliable & give better discrimination & accurate characteristics.

\* power transformers :- A power transformer is used in a sub-station to step up or step-down the voltage.

Except at the power station, all the subsequent sub-stations use step-down transformers to gradually reduce the voltage of electric supply and finally deliver it at utilisation voltage. The modern practice is to use 3-phase transformers in substations, even 3 single phase bank of transformers can be used.

\* The use of 3-phase transformer permits two advantages

- 1) Only one 3 phase load tap changing mechanism can be used.
- 2) 3-phase transformer installation is much simpler than three single phase transformer.

The transformer specification includes

- |                  |                    |                                 |
|------------------|--------------------|---------------------------------|
| 1) kVA rating    | 4) Rated frequency | 7) Type of core                 |
| 2) Rated voltage | 5) connections     | 8) type (power or distribution) |
| 3) No of phases  | 6) Tapping if any  | 9) Ambient Temperature          |

\* ~~High Voltage~~

\* High voltage disconnect switches [isolators & trays] :-

In sub-stations, it is often desired to disconnect a part of the system for general maintenance and repairs. This is accomplished by an isolating switch or isolator.

\* An isolator is essentially a knife switch and it is designed to open a circuit under no load. In other words, isolator switches are operated only when the line in which they are connected will not carry current.



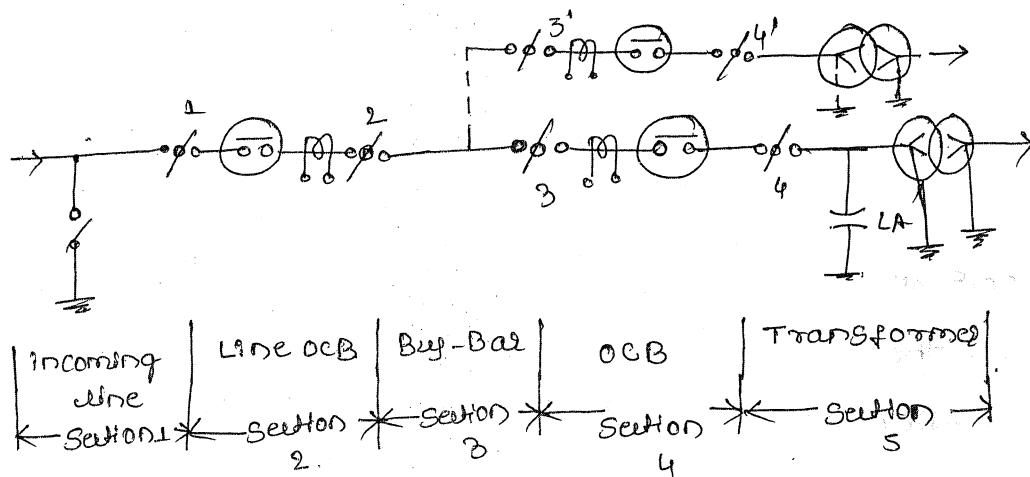

Fig - typical sub-station

- The above fig shows use of isolators in a typical sub-station, The entire substation is divided into 5 sections
- \* Each section is disconnected with the help of isolators for repair and maintenance purpose.
  - \* for example if section 2 is taken for repair purpose initially, open the oCB in this section & then open isolators 1 and 2, once section is repaired, close isolators 1 & 2 first & then the oCB.
  - \* High voltage insulators :- The insulators serve for two purposes. They support conductors (or bus bars) and confine the c/s to the conductors.
  - \* most commonly used material for insulator is porcelain
  - \* There are several types of insulators (pin type, suspension type, post insulator etc).
  - \* The use of insulator in sub-station depends upon the service requirement, for example post insulator is used for buy-bar,
  - \* A post insulator consists of a porcelain body cast

iron cap and flanged cast iron base. The hole in the cap is threaded so that buy-bay can be directly bolted to the cap.

\* Voltage Regulators :- voltage regulators are the devices which are used to supply the regulated voltage to power systems.

Voltage regulator is designed to maintain a constant voltage level automatically. depending upon the design, it may be used to regulate one or more AC or DC voltages. In an electronic power plants, the voltage regulators may be installed at a substation or along distribution lines so that all customers receive steady voltage independent of how much power is drawn from the line.

\* Storage Batteries :- In electric power stations and large capacity substations, the operating and automatic control ~~and~~ circuits, the protective relay systems, as well as emergency lightning circuits, are supplied by station batteries.

\* The latter constitute independent sources of operative and guarantee operation of the above mentioned circuits irrespective of any fault which has occurred in the station or substation, even in the event of complete disappearance of the ac supply in the installation.

\* station batteries are assembled of a certain number of accumulator cells depending on the operating voltage of the respective dc circuits.

Lead-acid batteries are most commonly used in power stations and substations because of their higher cell voltage & low cost.

\* Measuring instruments :- Ammeters, volt meters, watt meter, kWh meters, kVARh meters, power factor meters, reactive volt-ampere meters are installed in substations to control & maintain a watch over the cin flowing through the circuit and over the power loads.

\* power line carrier communication equipment :-

Such equipment is installed in the substations for communication, relaying, telemetering or for supervisory control. The equipment is suitably mounted in a room known as carrier room and connected to the high voltage power circuit.

\* Interconnection of power stations.

The connection of several generating stations in parallel is known as interconnected grid system.

The various problems facing the power station engineers are reduced by interconnecting different power stations in parallel.

\* even though the interconnection of station includes extra cost, yet considering the benefits, nowadays such aim is gaining more importance.

\* Some advantages of interconnected power station are as follows =>

1) Exchange of peak loads :- The peak load of the power station can be exchanged with the help of interconnected SIm.

If the load curve of a power station shows a peak demand which is greater than the rated capacity of the plant, then excess load can be shared by the other stations interconnected with it.

2) use of older plants :- The interconnected power SIm make it possible to use the older plants & less efficient plants to carry peak load for short duration.

3) Ensure economical operation :- interconnected power SIm make the operation of concerned power station quite economical, because the sharing of load among the station is arranged such that, more efficient stations operate continuously throughout the year at a higher load factor & less efficient plants work only for peak load condition.

4) increase diversity factor

5) ~~Reduce~~ reduce plant reserve capacity

6) Increase the reliability of supply.

\* ~~Example~~